

**SVS**

# SLEDGE STA-1200D 13-ULTRA UPGRADE KIT



*Remove old amplifier.*



*Install new 13-Ultra Amplifier Upgrade Kit,  
featuring SVS Subwoofer Control App.*

OWNER'S MANUAL

**AMPLIFIER FEATURES**

- Massively powerful Sledge 1,200-watt continuous Class D design with 4,200 watts of Peak Power.
- Unmatched intelligence from user adjustable low pass, phase, polarity and room gain compensation with three parametric EQs and port tuning (Ported models only) for absolute best alignment with speakers and optimized performance in any room.
- Groundbreaking SVS Bluetooth DSP control app for iOS and Android devices with three user presets allow custom tuning for every room and system.
- High efficiency cool-running Class D switching topology with massive 32 Amp 600 Volt MOSFET's result in lower EMI and highest efficiency while providing effortless power to produce SPLs and low frequency output with pristine clarity well beyond reference listening levels.
- High resolution 50Mhz Analog Devices Audio DSP with double precision 56bit filtering is the most advanced subwoofer processor available for perfect audio reproduction.
- 100v-240v full range input active Power Factor Correction (PFC) pre-regulates mains to solid 360V DC regardless of mains voltage or quality so the sound quality never falters no matter what's coming out of the wall.
- Active PFC lowers average current and smooths mains input current allowing for 1200W output from a standard 15A mains circuit.
- XLR and RCA stereo input/output with ultra-wide input voltage for consumer and professional audio applications.
- Variable port tuning with standard, extended and sealed modes for easy optimization of output based on listening preferences and content.
- Auto/On and 3-30V AC/DC trigger for maximum installation convenience.
- Input impedance 22kohm (unbalanced RCA)/ 22kohm (balanced XLR).
- Green 0.5-watt low standby power consumption.
- RoHS compliant, lead-free construction, world-wide safety certifications.

**SVS APP FEATURES**

- The most powerful and flexible Bluetooth controlled subwoofer DSP app, works with both iOS and Android operating systems.
- Easiest and most convenient way to adjust crossover frequencies, parametric EQ, polarity, room gain and all other bass management functions.
- Convenient custom presets allow for perfect tuning in any room or system, from your favorite seat.
- Easy-to-follow tutorial provides clear guidance for all functions.

The SVS 13-Ultra is designed for easy set-up and integration in both multi-channel home theater and two-channel (stereo) systems. It is best to familiarize yourself with the subwoofer connections and the rear panel of your AV receiver or preamplifier before setting your subwoofer up. **Be sure your 13-Ultra is switched to Off before plugging it in or connecting to your AV receiver.** It's also best to use cables with secure connections for optimal bass performance.

We've developed the convenient SVS mobile app for both Apple® iOS® and Google Android™ that allows you to make adjustments for room layout, personal preferences, movies vs. music, and more. It's the best way to fine tune your subwoofer for perfect performance from the comfort of your favorite seat.

A full explanation of all the advanced subwoofer DSP controls is available in this owner's manual, as well as in the SVS subwoofer app tutorial. The following sections cover basic connections and control settings when integrating the 13-Ultra into a surround sound or two channel system.

**BACK PANEL FEATURES**

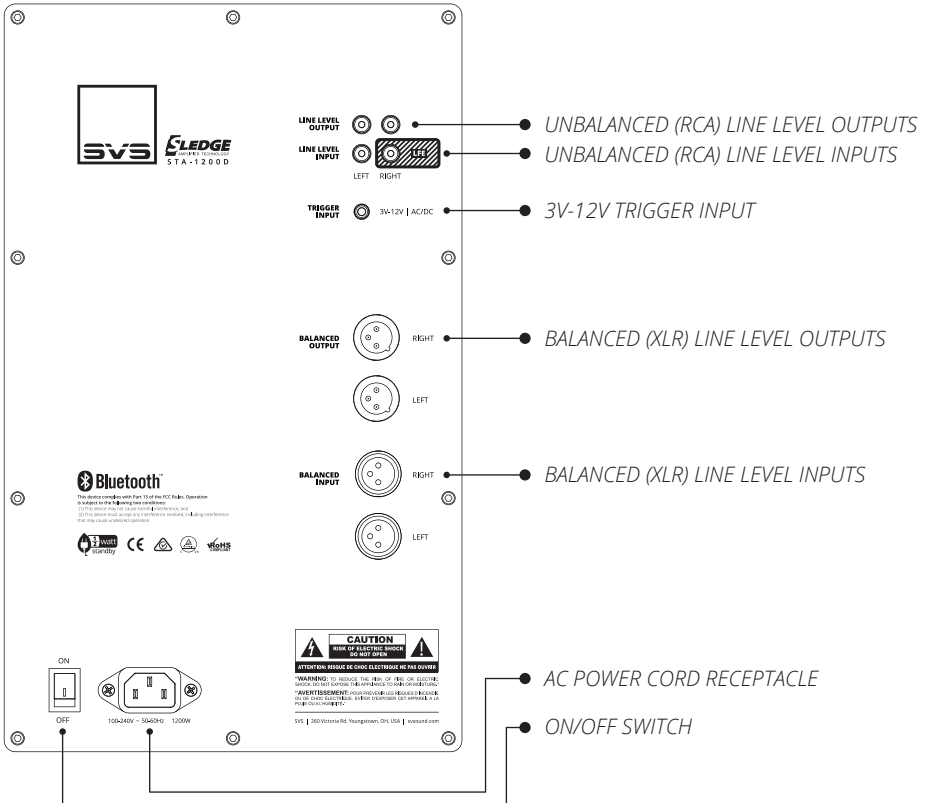

## AC Power Connection

Connect the subwoofer power cord to the subwoofer amplifier and directly into an AC outlet. Convenience outlets located on the rear panel of some AV receivers or pre/pros are NOT recommended for your 13-Ultra as these outlets are not meant for high power devices.

## Line Level Connection – Single LFE Channel

The most common way to connect your 13-Ultra is with a single RCA or XLR interconnect cable going from the LFE or SUB1 Output on your AV receiver or preamplifier to the LFE Input on your 13-Ultra. This allows your processor to perform the upstream bass management and send the subwoofer a pre-filtered mono signal.

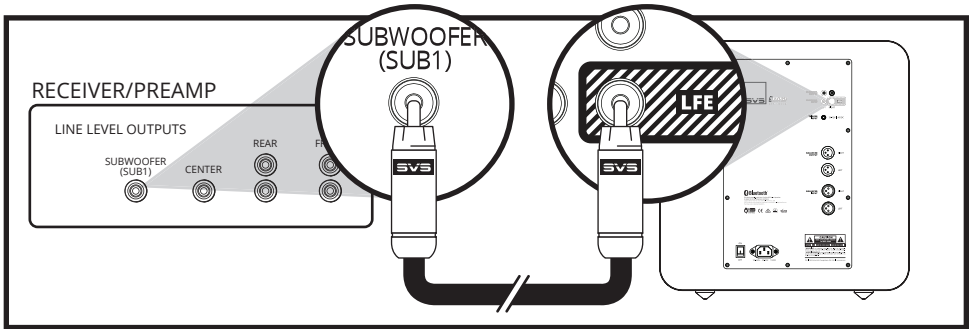

## Line Level Connection – Stereo Receiver or Preamplifier Left/Right Channels

Both Left and Right inputs on your 13-Ultra can be used in a two-channel stereo application with a stereo preamplifier that has Left and Right line level or Balanced (XLR) outputs.

Connect the left and right outputs of your preamplifier to the left and right line level inputs of the 13-Ultra using RCA or XLR interconnects.

**Line Level Connection – Stereo Receiver or Preamp Left/Right Channels (cont'd)**

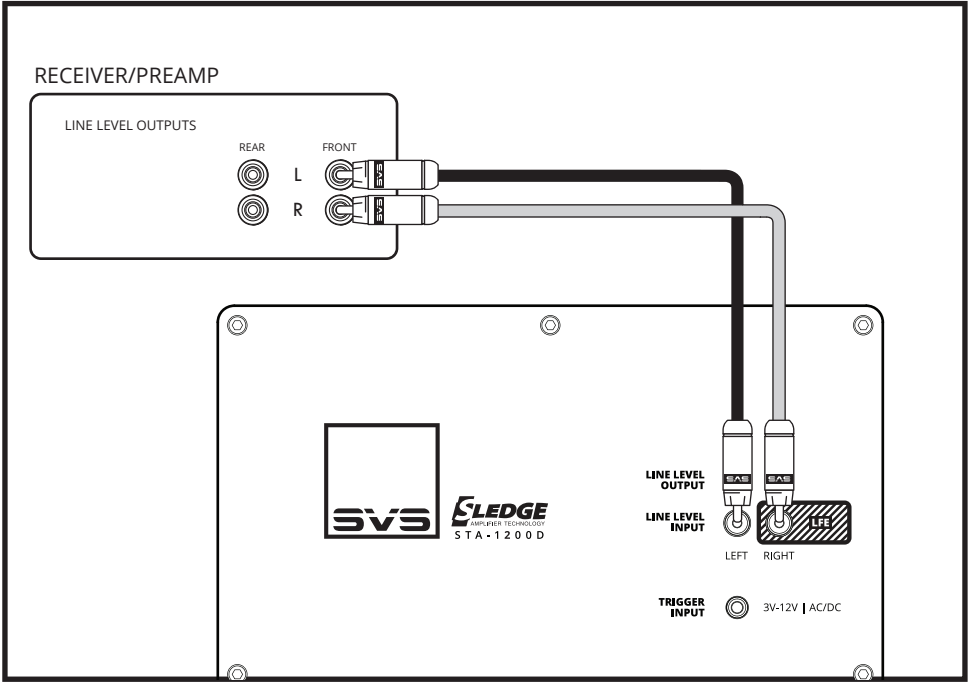

Enable and adjust the on-board low pass filter of the 13-Ultra for a smooth blend with the main speakers.

*NOTE: For additional guidance on speaker/subwoofer crossover settings, please consult our Sound Experts or our Merlin subwoofer matching tool at [www.svsound.com/merlin](http://www.svsound.com/merlin).*

[www.svsound.com](http://www.svsound.com) • [custservice@svsound.com](mailto:custservice@svsound.com) • (877) 626-5623

**3V-12V Trigger Input**

This feature will automatically turn the subwoofer on/off when a signal is sent to the trigger input from another component in the system (typically the pre/pro or AV receiver). The other component in the system must be equipped with a trigger output feature and requires a TS 1/8" mono cable (pictured below).

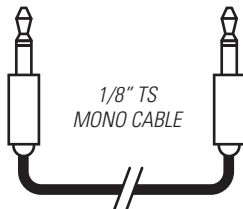

## Connecting Multiple Subwoofers or “Going Dual”

Running two or more subwoofers has many acoustic benefits such as: improved frequency response throughout the listening area, fewer peaks and nulls, increased output and decreased bass localization. The RCA and XLR Outputs provide an easy way to integrate multiple 13-Ultras or other subwoofers into your audio system.

Many AV Receivers and Surround Processors have more than one subwoofer output. As described previously, you can run a single connection from each subwoofer output to each of your subwoofers.

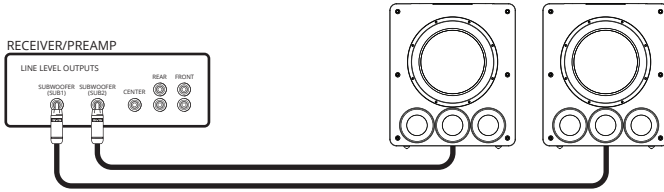

If you have more subwoofers than Sub Outputs from your AV Receiver, an easy solution is to use an RCA splitter or RCA Y-adapter to divide the subwoofer output. This is the most commonly recommended way to connect multiple subwoofers when there is only one Sub Out.

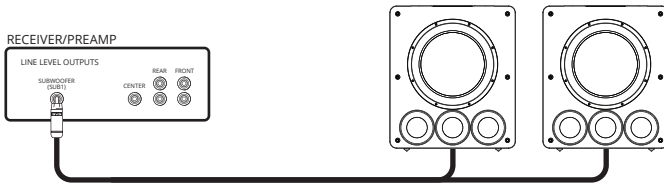

Another option is to use the Left and Right RCA or XLR outputs on the 13-Ultra to Daisy Chain additional subwoofers. It's important to use the matching output and input terminals. For example, if you are using the RCA inputs, be sure to use the RCA outputs to daisy chain to the next subwoofer.

*NOTE: While the settings of each subwoofer should be similar, you will probably find that each sub will need to be calibrated for optimal performance because of its unique room placement. Regardless of how you use your subwoofer, experimentation can often result in better sound. Don't be afraid to try different settings, you can always return the controls to their defaults.*

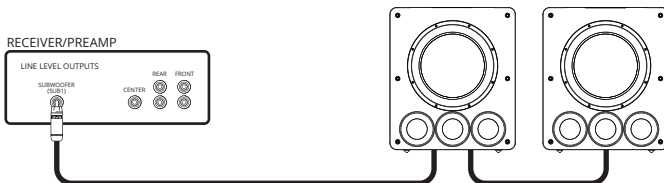

**Connecting Multiple Subwoofers or “Going Dual” (cont’d)**

In a 2-channel system you can set up Stereo Subwoofers, where one is used for the Left Channel and one for the Right Channel. Typically, the subwoofers will be symmetrically placed according to your speakers. And be sure to maintain all the correct Left and Right output and input connections to ensure optimum performance.

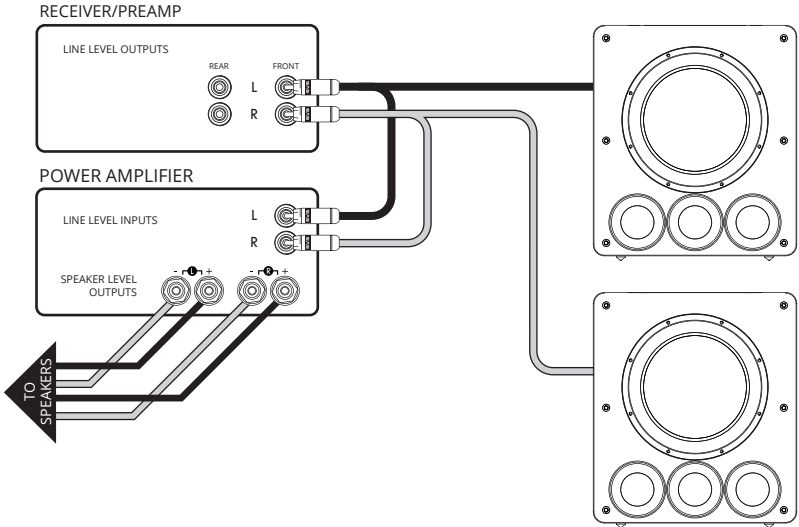

## Control Settings for AV Receiver & Processor

If using your 13-Ultra subwoofer with an AV Receiver or preamp with bass management, it is recommended to leave all control settings in the default position, aside from the volume, which allows you to adjust the level of output based on your personal preferences. Set the 13-Ultra volume to -10 before running auto-set-up in the AV receiver/processor.

*NOTE: Always re-run AV Receiver auto-set-up after moving the subwoofer to a different location to ensure the acoustic distance and calibration levels are set correctly.*

*NOTE: If you want to run the subwoofer louder than the initial auto-set-up level, adjust the subwoofer channel level upward in the AV receiver menu until you get the experience and performance you want. An increase of 2-4 dB louder than initial set-up level is common for many customers.*

Please consult the Advanced Subwoofer Controls section of this owner's manual or contact our SVS Sound Experts if you have questions about any of the control settings.

[www.svsound.com](http://www.svsound.com) • [custservice@svsound.com](mailto:custservice@svsound.com) • (877) 626-5623

## Control Settings for Stereo Receiver or Pre-Amplifier

Most Stereo Receivers and Pre-Amplifiers do not have bass management. Instead you will use the Left and Right full-range outputs and make adjustments through the DSP amplifier on the subwoofer.

Be sure to connect both Left and Right outputs to the Left and Right inputs on the subwoofer.

Set the Low Pass Filter to "On" and adjust the Crossover Frequency and Slope to achieve a smooth blend and transition with the main speakers.

Once blended, adjust the Subwoofer volume to match the volume level of your main speakers.

For finer tuning, our **Subwoofer Matching Tool** provides the recommended low pass filter frequency and slope setting for most loudspeakers on the market. Just choose your brand and model of speakers from the menus and the Subwoofer Matching Tool does the rest. It's available 24/7, 365 at [www.svsound.com/merlin](http://www.svsound.com/merlin). Our SVS Sound Experts are also standing by to help with any connection or control questions you have about any of the controls or settings.



Placement of subwoofers is a process driven by competing variables that differ in every home. Décor, floor space, furniture, speaker placement, seating location, and of course, sound quality all factor into the decision of where a subwoofer should be placed. If you have flexibility, there's an artistry to subwoofer placement that can be aided by understanding some basic acoustic principles and set-up techniques.

If you are limited to a single subwoofer location, it's best to find the ideal listening location in the room. You'll notice as you move through the room, bass response will vary significantly. This is due to the complex pattern of standing sound waves in the room. Sometimes simply moving a few feet in any given direction can improve the balance and accuracy dramatically. Once you find the 'subwoofer sweet spot' in the room – reserve that seat for yourself!

### **Corner Placement**

Corner placement of a subwoofer reduces the potential to encounter nulls, which are acoustic cancellation points or 'dead spots' in the room. While this can often make for hugely impactful bass, it can sometimes result in a "boomy" sound depending on your listening position. If you experience this, you can use the tuning controls to blend your 13-Ultra more smoothly with your speakers or try pulling it further away from the walls to smooth out the bass response.

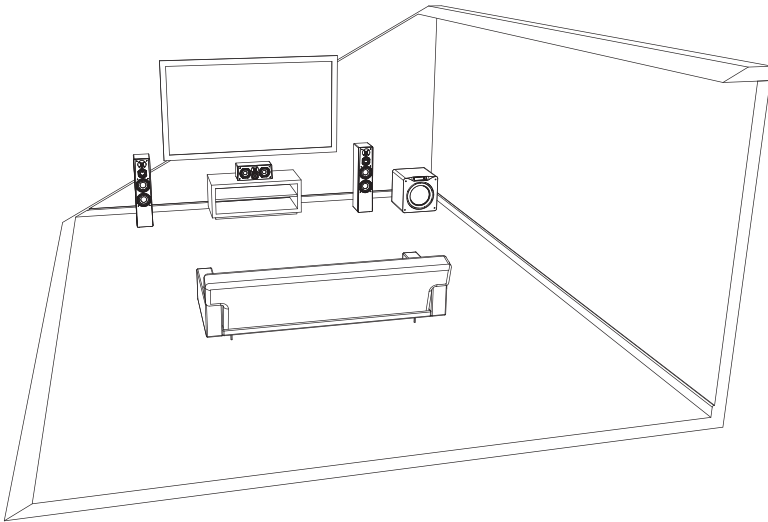

### Front Placement

Front of the room placement in between or just to the side of the front channel speakers is another common choice. Front of the room placement usually results in the best blending with the main speakers and center channel and minimizes localization effects.

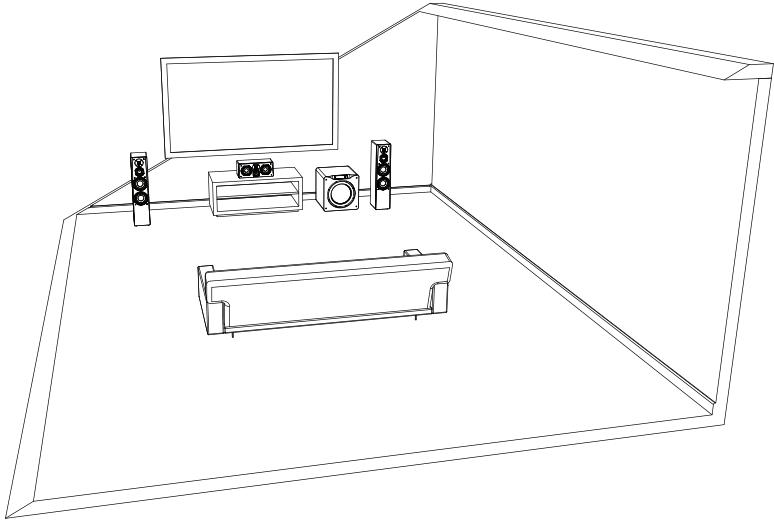

### Side Wall Placement

Side wall placement is less frequently used but can be an effective subwoofer location for excellent accuracy and output.

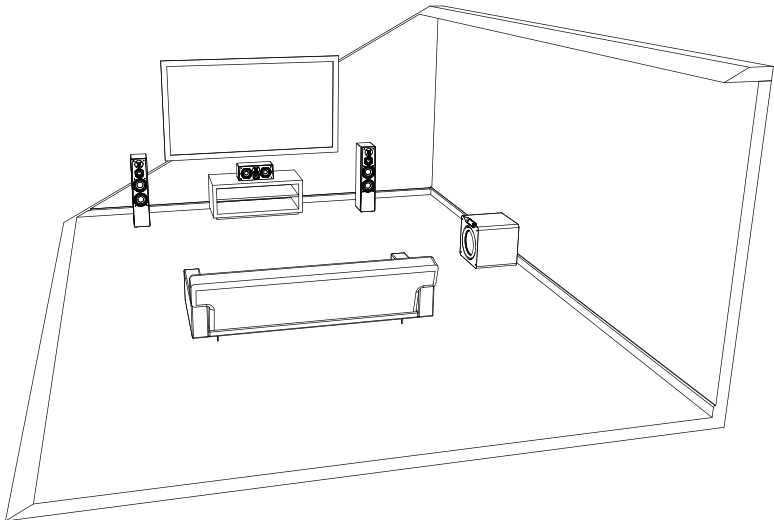

## Dual Subwoofer Placement

Based on our own extensive testing, and research done by the professional audio community, we recommend the following placement options for dual subwoofers:

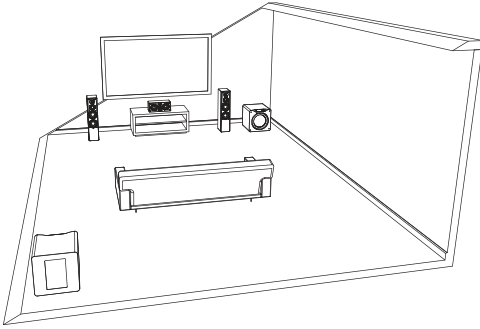

- Opposite diagonal front/rear corners.

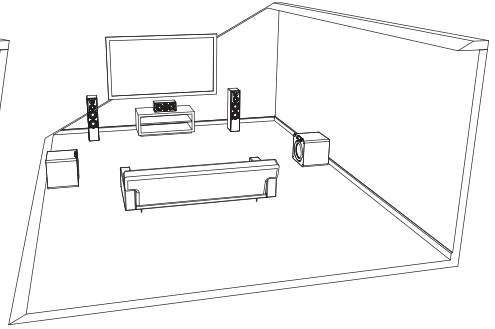

- At the mid-points of the side walls.

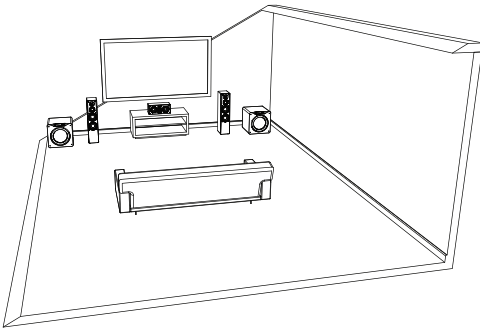

- Front stage in the corners.

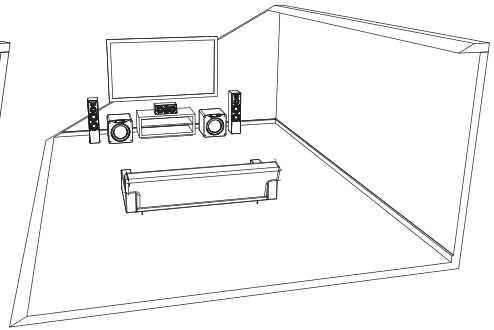

- Front stage flanking the center channel to the inside of the main speakers.

While the first two options are proven performers with typically excellent results, they are often difficult to implement in a living/family room environment. All rooms are different, so we recommend staying flexible and trying all possible placement options for the best results.

Your SVS 13-Ultra Subwoofer can only be controlled from the SVS Mobile App, for unprecedented flexibility when optimizing performance for room layout, speakers, system set-up and more.

### SVS Bluetooth App

Our groundbreaking SVS Subwoofer DSP app is available for free via the Apple® App® Store and Google Play™ Store. Just search “SVS App” and follow the prompts to download to your mobile device. Once installed, there’s a helpful tutorial that will guide you through each option and provide common settings to simplify the process. The SVS App is the only way to access all of the advanced control features available on your 13-Ultra and it is the most convenient option for controlling every feature.

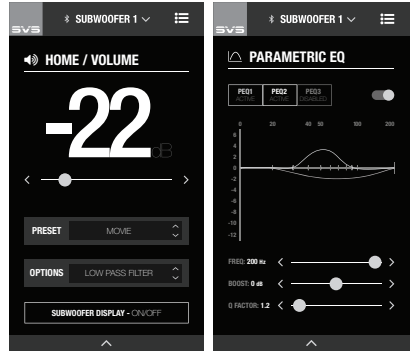

## **Volume**

Setting the level too high will cause the bass to seem bloated and is the single most common cause of bad sounding subwoofers. A rule of thumb is that the subwoofer should not draw attention to itself, but should simply make the systems low end seem more extended and accurate. Different content has different levels of output so adjust volume based on source material and your personal preference.

## **Low Pass Filter**

Enables smooth sonic transition and flat frequency response between speakers and the subwoofer. This allows you to control the upper frequency cut-off to blend with main speakers. It also allows you to adjust slope, or the rate at which the low pass filter rolls off. If using an AV Receiver with a Subwoofer Output, leave in the OFF position.

## **Phase Adjustment**

Solves sound wave cancellation issues at specific frequencies and perfectly aligns the arrival of output from speakers and subwoofers to your listening position. Normally set to 0° if the subwoofer is near the main speakers. Adjusting Phase shifts timing of the subwoofer output to align with the main speakers or additional subwoofers.

## **Polarity**

In some cases, reversing polarity solves dips or humps at the crossover frequency between a subwoofer and speaker and can be used to fix bass nulls or overly boomy spots in the listening area. Reversing the electrical polarity of the subwoofer amplifier makes it so the woofer moves in when speaker drivers move out and is normally set to positive

## **Parametric EQ**

Powerful tool for removing peaks and dips in your listening area, and for creating custom subwoofer output based on personal listening preferences. Works best when used with acoustic measurements.

Allows you to set the desired center frequency of the filter, increase or decrease the SPL dB of the filter, or adjust the bandwidth of the filter.

## **Room Gain Compensation**

Fixes bloated sounding bass by optimizing low frequency output and extension when too much sound wave density is being created by a small room.

## Presets

Allows up to three pre-saved settings for movie, music and custom. This enables easy switching to optimize your 13-Ultra's output and settings based on your specific listening preferences with different kinds of content. When using the SVS App, these presets can be renamed as desired.

## Port Tuning

Port blocking allows custom tuning of your ported 13-Ultra Subwoofer based on listening preference by exchanging max output for low frequency depth and quickness. When using the feature, always match port blocking with the selected tuning via the SVS Subwoofer App.

Three tunings are available:

*Standard Tune* = All ports open (highest maximum output)

*Extended tune* = One port plugged (deeper extension, slightly less maximum output)

*Sealed tune* = All ports plugged (best transient response)

## System Settings

Allows you to adjust subwoofer stand-by mode and also reset the subwoofer to factory settings.

### Subwoofer Name

Customize the name of your subwoofer for easy preset switching. (Exclusive SVS App Feature)

### Subwoofer Standby

Choose whether to have your subwoofer in Auto, On (Default), or Trigger mode.

### Reset

Resets 13-Ultra Subwoofer back to original Factory Settings.

### About this App

Provides version number and other information about the SVS App and also allows you to turn performance monitoring on/off.

**FEATURE OPTIONS & RANGES**

**FEATURE**

**RANGE / OPTION**

**Volume**

*-60dB - 0dB (1dB/step)*

**Low Pass Filter**

LP Frequency: *30Hz - 200Hz (1Hz/step)*  
LP Slope: *6dB, 12dB, 18dB, 24dB*

**Phase**

*0° - 180° (1degree/step)*

**Polarity**

*Positive (+) / Negative (-)*

**Parametric EQ**

PEQ Frequency: *20, 22, 25, 28, 30 - 200Hz (1Hz/step)*  
PEQ Boost: *-12.0 - 6.0dB (0.1dB/step)*  
PEQ Q Factor: *0.2 - 10.0 (0.1/step)*

**Room Gain Comp**

RGC Frequency: *25Hz, 31Hz, 40Hz*  
RGC Slope: *6dB, 12dB*

**Port Tuning**

*Standard / Extended / Sealed*

- Read these instructions.
- Keep these instructions.
- Heed all warnings.
- Follow all instructions.
- Do not use this apparatus near water.
- Clean only with dry cloth.
- Do not block any ventilation openings. Install in accordance with the manufacturer's instructions.
- Do not install near any heat sources such as radiators, heat registers, stoves, or other apparatus (including amplifiers) that produce heat.
- Do not defeat the safety purpose of any polarized or grounding-type plug. A polarized plug has two blades with one wider than the other. A grounding type plug has two prongs and a third grounding point. The wide blade or the third prong are provided for your safety. If the provided plug does not fit into your outlet, consult an electrician for replacement of the obsolete outlet.
- Protect the power cord from being walked on or pinched particularly at plugs, convenience receptacles, and the point where they exit from the apparatus.
- Only use attachments/accessories specified by the manufacturer.
- Use only with the cart, stand, tripod, bracket, or table specified by the manufacturer, or sold with the apparatus. When a cart is used, use caution when moving the cart/apparatus combination to avoid injury from tip-over.
- Unplug this apparatus during lightning storms or when unused for long periods of time.
- Refer all servicing to qualified service personnel. Servicing is required when the apparatus has been damaged in any way, such as power-supply cord or plug is damaged, liquid has been spilled or objects have fallen into the apparatus, the apparatus has been exposed to rain or moisture, does not operate normally, or has been dropped.
- **WARNING:** To reduce the risk of fire or electric shock, this apparatus should not be exposed to rain or moisture and objects filled with liquids, such as vases, should not be placed on this apparatus.
- This apparatus conforms to the use requirement in tropical and moderate climates, with a maximum temperature of the environment not exceeding 45°C (113°F).
- If the subwoofer is to be used in a confined space (e.g. built into furniture), the space must be ventilated to allow sufficient air to circulate and cool the unit.
- To completely disconnect this equipment from the mains, disconnect the power supply cord plug from the receptacle.
- The mains plug of the power supply cord shall remain readily operable.



The lightning flash with arrowhead symbol within an equilateral triangle is intended to alert the user to the presence of uninsulated "dangerous voltage" within the products enclosure that may be of sufficient magnitude to constitute risk of electric shock to persons.



The exclamation point within a triangle is intended to alert the user to the presence of importance operating and maintenance (servicing) instructions in the literature accompanying the product.



**WARNING!**

DO NOT INGEST BATTERY, CHEMICAL BURN HAZARD

The remote control supplied with this product contains a coin/ button cell battery. if the coin/button cell battery is swallowed, it can cause internal burns in just 2 hours and can lead to death.

Keep new and used batteries away from children. if the battery compartment does not close securely, stop using the product and keep it away from children. If you think batteries might have been swallowed or placed inside any part of the body, seek immediate medical attention.

**AVERTISSEMENTS!**

N'INGÉREZ PAS LES PILES. BRÛLURE CHIMIQUE

La télécommande fournie avec ce produit contient une pile bouton. Si la pile bouton est avalée, elle peut entraîner de très graves brûlures internes en à peine 2 heures et la mort.

Conservez les piles, nouvelles ou usagées, hors de portée des enfants. Si le compartiment des piles ne se ferme pas correctement, n'utilisez plus le produit et conservez-le hors de portée des enfants. Si vous pensez que des piles ont été ingérées ou placées dans n'importe quelle partie du corps, consultez immédiatement un médecin.

## FCC Statement

This device complies with part 15 of the FCC Rules. Operation is subject to the following two conditions: (1) This device may not cause harmful interference, and (2) this device must accept any interference received, including interference that may cause undesired operation.

This device must not be co-located or operating in conjunction with any other antenna or transmitter.

This equipment has been tested and found to comply with the limits for a Class B digital device, pursuant to part 15 of the FCC Rules. These limits are designed to provide reasonable protection against harmful interference in a residential installation. This equipment generates, uses and can radiate radio frequency energy and, if not installed and used in accordance with the instructions, may cause harmful interference to radio communications. However, there is no guarantee that interference will not occur in a particular installation. If this equipment does cause harmful interference to radio or television reception, which can be determined by turning the equipment off and on, the user is encouraged to try to correct the interference by one or more of the following measures:

- Reorient or relocate the receiving antenna.
- Increase the separation between the equipment and receiver.
- Connect the equipment into an outlet on a circuit different from that to which the receiver is connected.
- Consult the dealer or an experienced radio/TV technician for help.

To comply with FCC's and Industry Canada's RF radiation exposure limits for general population/uncontrolled exposure, this device must be installed to provide a separation distance of at least 20cm from all persons.

*WARNING: Any changes or modifications to this unit not expressly approved by the party responsible for compliance could void the user's authority to operate the equipment.*

## IC Statement

This device complies with Industry Canada licence-exempt RSS standard(s). Operation is subject to the following two conditions: (1) this device may not cause interference, and (2) this device must accept any interference, including interference that may cause undesired operation of the device.

Le présent appareil est conforme aux CNR d'Industrie Canada applicables aux appareils radio exempts de licence. L'exploitation est autorisée aux deux conditions suivantes: (1) l'appareil ne doit pas produire de brouillage, et (2) l'utilisateur de l'appareil doit accepter tout brouillage radioélectrique subi, même si le brouillage est susceptible d'en compromettre le fonctionnement. The device is compliance with RF field strength limits, users can obtain Canadian information on RF exposure and compliance.

Le présent appareil est conforme de ce matériel aux conformités ou aux limites d'intensité de champ RF, les utilisateurs peuvent sur l'exposition aux radiofréquences et la conformité d'acquérir les informations correspondante.

This Class B digital apparatus complies with Canadian ICES-003.

Cet appareil numérique de la classe B est conforme à la norme NMB-003 du Canada.

CAN ICES-3 (B) /NMB-3(B)

Our SVS Sound Experts are standing by from Monday to Friday from 9AM-9PM ET, Saturday from 12PM-6PM, and Sunday from 12PM-4PM to assist you with subwoofer set-up and optimization, AV Receiver settings and more. They can be reached by phone, email or chat via the options below.

***www.svsound.com • custservice@svsound.com • (877) 626-5623***

We also invite you to share a review on our website and to join our fun and active social media community where we share reviews, featured systems, interesting audio articles and more.



Post at [facebook.com/SVSound](https://www.facebook.com/SVSound)



Tweet @[SVS\\_Sound](https://twitter.com/SVS_Sound)



Follow [instagram.com/SVS\\_Sound](https://www.instagram.com/SVS_Sound)



Watch at [youtube.com/c/SVS\\_Sound](https://www.youtube.com/c/SVS_Sound)

